



**DEV COMPONENTS**  
PRIVATE LIMITED

Manufacturers of Motor Stampings, Electrical Laminations  
E&I Strip Laminations, Mitre Cut Laminations & Special Components



Version Dt. 01.10.22  
Revision Dt. 16.08.23  
Revision No.04.01

# Company Profile



Click E-Links



**DEV COMPONENTS**  
PRIVATE LIMITED

Manufacturers of Motor Stampings, Electrical Laminations  
E&I Strip Laminations, Mitre Cut Laminations & Special Components

Managing Director

**Mr. Dhananjaya.A**

Bachelor in Engineering

30+ Years of Expertise

**P +91 99456 71218 | +080 4212 3195**

**E md@devcomponents.in | daswath@gmail.com**

website : <https://stampinglaminations.com>





**DEV COMPONENTS**  
PRIVATE LIMITED



Click E-Link  
for  
Directions



## Company Infrastructure

### Registered Office

No. 83, 4th Cross, R.K.Layout 2nd Stage, Padmanabha Nagar,  
Bangalore – 560070, Karnataka, India

Since 1991

### Factory 01

1/400, Hoody,  
Near ABT Go down,  
Mahadevpura,  
Whitefield Road  
Bangalore – 560070

### Factory 02

Site 29, Sy 7/2,  
Kachohalli Industrial Area,  
Magadi Main Road,  
Vishwaneedam Post,  
Bangalore – 560091

### Factory 03

Site 30, Sy 7/2,  
Kachohalli Industrial Area,  
Magadi Main Road,  
Vishwaneedam Post,  
Bangalore – 560091

Manufacturers of Motor Stampings, Electrical Laminations  
E&I Strip Laminations, Mitre Cut Laminations & Special Components





## Vision

“Contribute to Conserve Energy & Preserve Future”

## Mission

“ Aim to Research & Develop High Quality Stamping Tools & Cater Competitively Priced A to Z High Quality Electrical Stampings & Laminations Across the Globe ”





**DEV COMPONENTS**  
PRIVATE LIMITED

# Quality Policy





**DEV COMPONENTS**  
PRIVATE LIMITED



# Quality Objectives

## Product

Reduction in defect rates, PPM, scrap rates, on-time delivery.



## Process

Improving productivity, reduction of waste, set-up times or rework, improved cycle times



## Customer

Product returns, reduction in complaints, improved on-time delivery.



## Suppliers

Reduction of complaints or defects, improved on-time delivery.



## Resources

Availability, capability, personnel, competency, efficiency, absenteeism.





**DEV COMPONENTS**  
PRIVATE LIMITED

# ORGANIZATION CHART

Updated July 2023

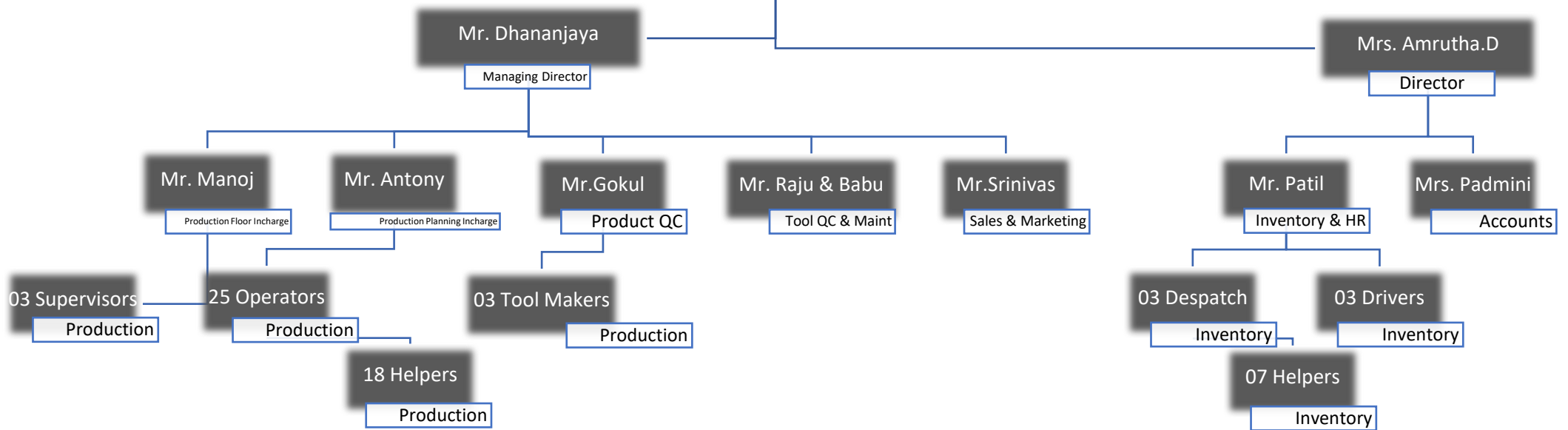



DEV COMPONENTS  
PRIVATE LIMITED



## Our Major Products

Manufacturing

- Stampings Dia from 30mm to 400mm, EI Laminations from Types EI19 to EI 350, in CRNGO All Grades.
- Cut to Length Strip Laminations with Holing in CRGO & CRNGO, products Range Strip Laminations, Mitre Cut Laminations.
- Specialized & Customized Designs as per Customer Requirement of Stamping and Lamination in CRNGO All Grades.

Distribution & Trading

- Prime CRNGO Coils of 0.20 mm to 0.50 mm Thickness, Width Ranging Up to 1000mm in all Grades
- Customized Cut To Length, Slit Coils in All Grades





DEV COMPONENTS  
PRIVATE LIMITED

# A to Z Motor Stampings “ You Name It, We Make It ”



# DEV's Specialized Manufacturing, Product Categories



### Motor Stampings



### Bonded & Special Purpose Cores



### Electrical Laminations

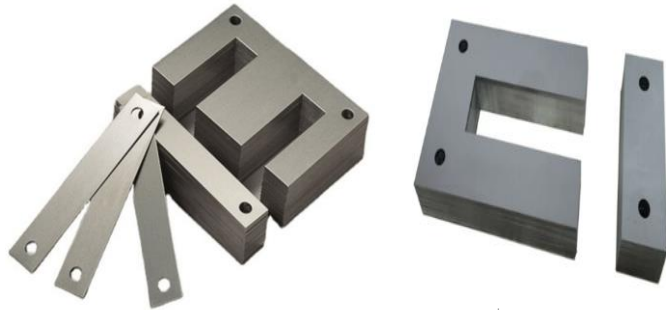

### Epoxy Coated Cores



### Linear Motor Stampings

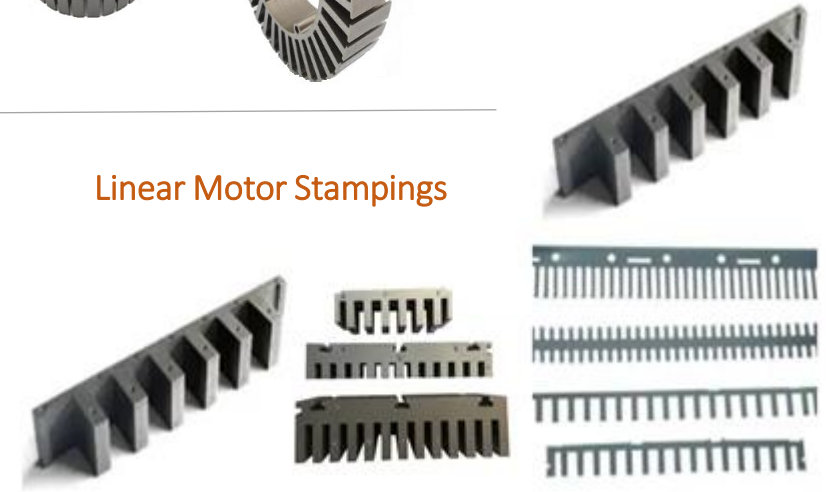

### Contactors Cores

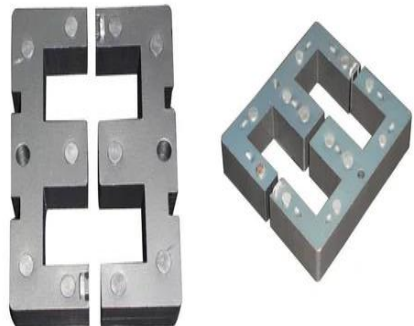

### Strip Laminations



### Miter Cut

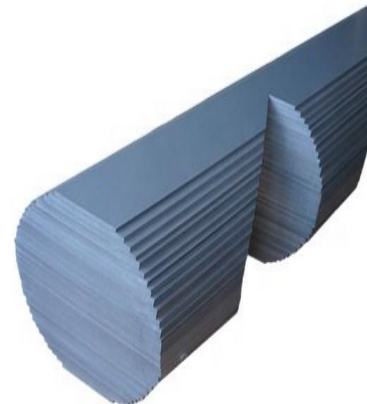

### Coils



CRGO Coils  
CRNGO Coils  
CRGO Pup Coils  
CRNGO Pup Coils  
GI Coils

CRCA Coils

CRNGO Slit Coils

PPGI Coils

# DEV's Actual Product Pictures



**DEV COMPONENTS**  
PRIVATE LIMITED

Since 1991



CRNGO Slit Coils



CRCA Coils  
CRGO Coils  
CRNGO Coils  
CRGO Pup Coils  
CRNGO Pup Coils  
GI Coils



You Name It, We Make It



Mixi Rotor Stampings



E & I Laminations



Industrial Motor Stampings



Motor Stampings for Electric Vehicles



High Speed Stators



PPGI Coils



CRNO Strip  
Laminations

# DEV's Specialized Tool Designing & Die Making Co-ordination

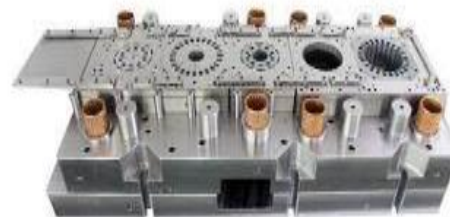
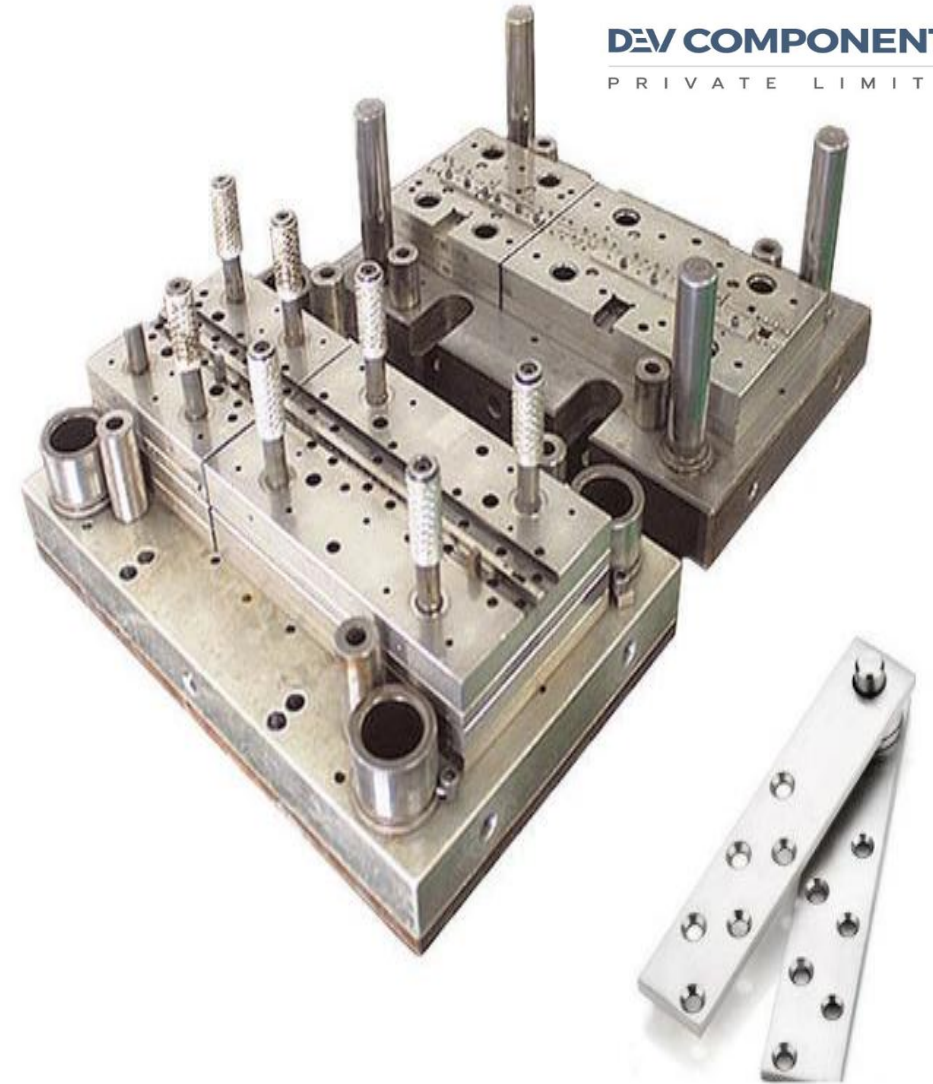
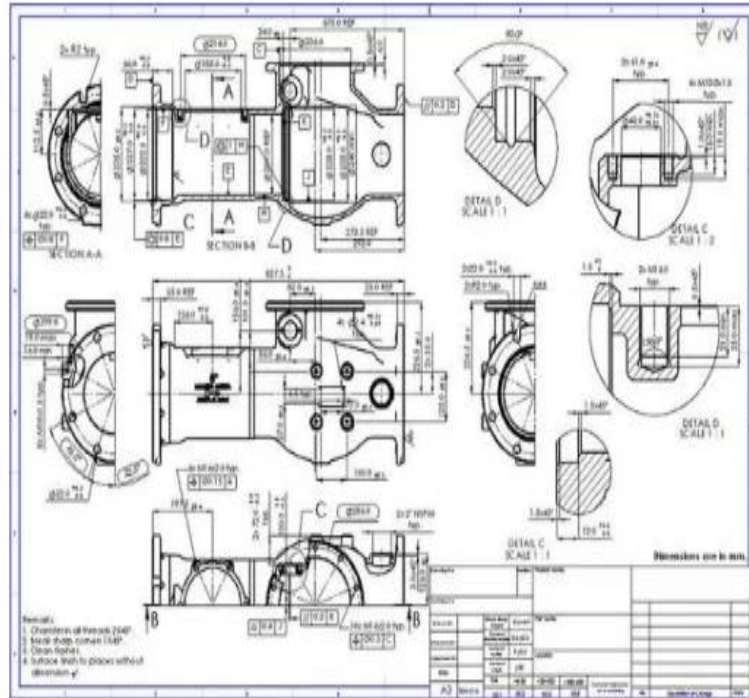
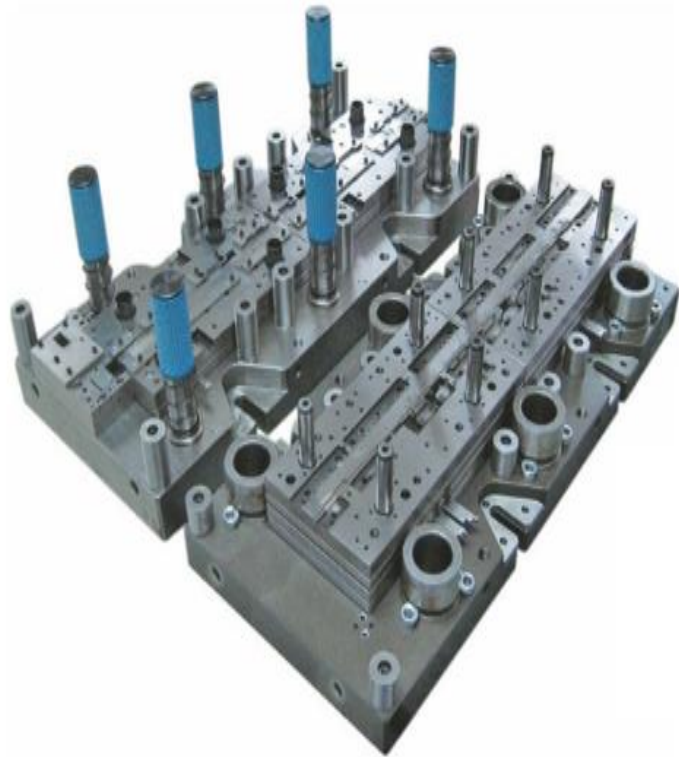

# DEV Factory

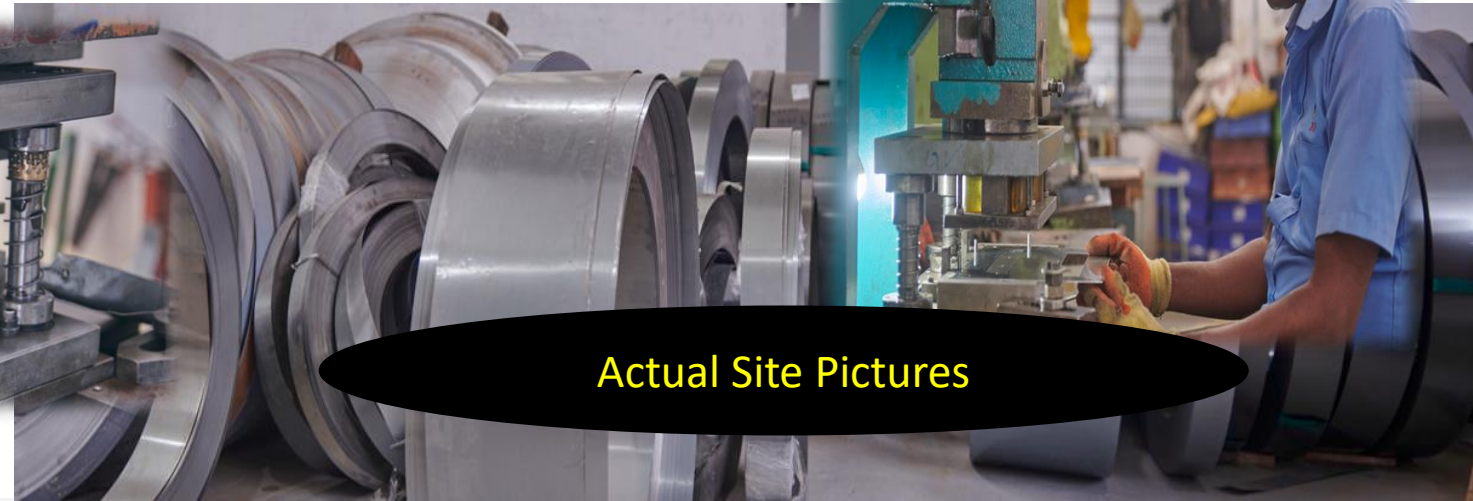

Actual Site Pictures



# High Speed Equipment @ DEV

High Speed Power Presses Range 20 Tons to 80 Tons & Automated Cut to Length Equipment



DEV COMPONENTS  
PRIVATE LIMITED

Since 1991



CRNGO Slit Coils



- CRCA Coils
- CRGO Coils
- CRNGO Coils
- CRGO Pup Coils
- CRNGO Pup Coils
- GI Coils

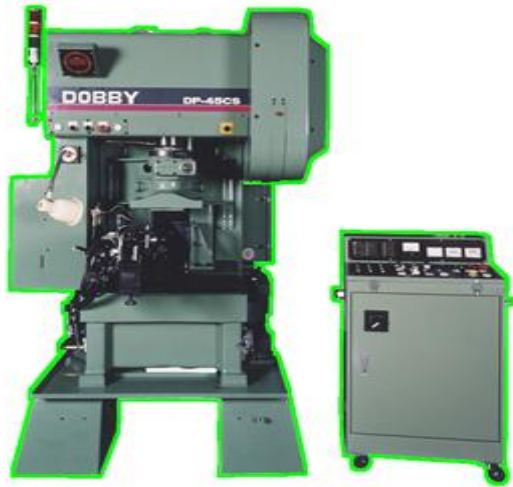

You Name It, We Make It



CRNO Strip Laminations



Mixi Rotor Stampings



E & I Laminations



Industrial Motor Stampings



Motor Stampings for Electric Vehicles



High Speed Stators



PPGI Coils

# DEV's Production Capabilities & Process



Since 1991

- Coil Slit & Batch Tracking
- Task Card Allotted to Track Performance
- Pre-Job QC for Damages, & Burrs
- Punching Using Presses
- Component Stacking, If Mandated
- On Spot QC & Inspection Certification
- Task Card Closure & Packing for Sale

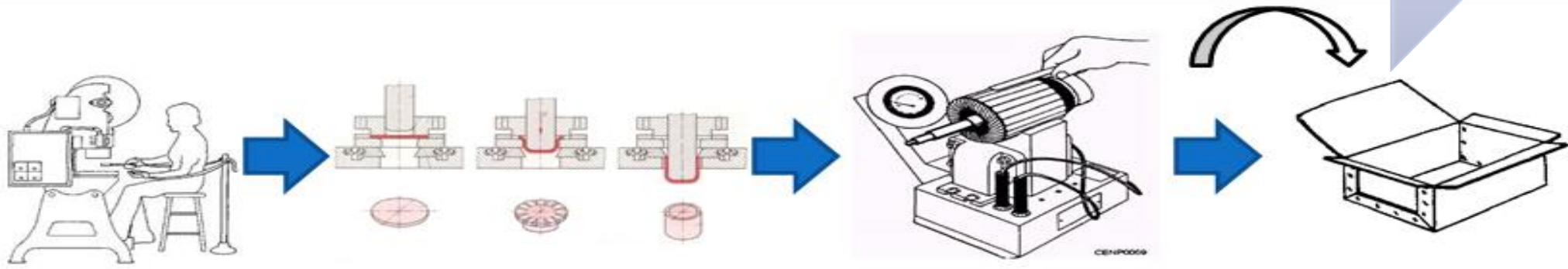

400+ Ton Production Per Month Capacity,  
With Special Capabilities to Gear Up Big Bulk Orders With a Short Notice



CRNGO Slit Coils



CRCA Coils  
CRGO Coils  
CRNGO Coils  
CRGO Pup Coils  
CRNGO Pup Coils  
GI Coils



PPGI Coils

You Name It, We Make It

CRNO Strip Laminations



Mini Rotor Stampings



E & I Laminations



Industrial Motor Stampings



Motor Stampings for Electric Vehicles



High Speed Stators

# Product Flow



01. Coil Slit Planning



02. Coils are Slit



03. Batchwise Slit Coils Ready for Stamping and Laminations



04. Tool Setting into Machine & Sampling & On Spot Sampling Starts



06. Manufactured Stocks & On Spot Quality Check & Control



05. Stamping & Lamination Products Manufacturing Done Basing Product Type in Different Machines

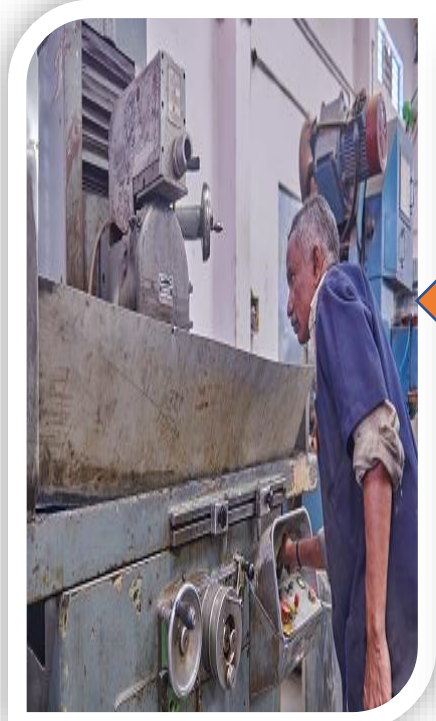

08. Periodic Grinding of Tools & Maintenance



07. Water Resistant Packs of Stocks Ready for Dispatch



# DEV's Quality Check & Tools



DEV COMPONENTS  
PRIVATE LIMITED

Since 1991



CRNGO Slit Coils



CRCA Coils  
CRGO Coils  
CRNGO Coils  
CRGO Pup Coils  
CRNGO Pup Coils  
GI Coils



PPGI Coils



Special QC, Using Certified Digital Vernier's, Micrometers, Surface Plates and Gauges



Special Assembly & Tool Rooms With Dedicated Qualified Man Power for Tool Maintenance

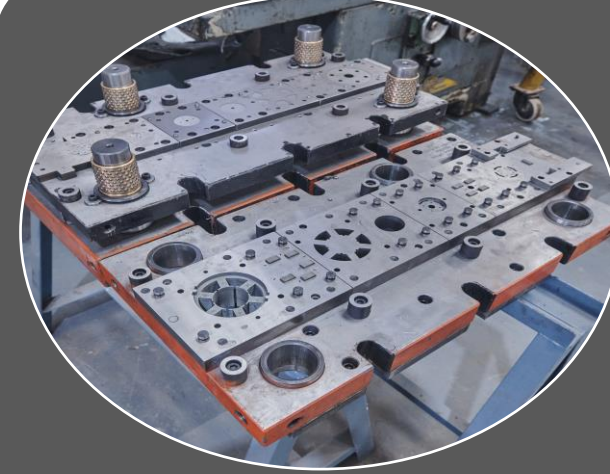

Special Tie Ups with Reputed Tool Rooms Across the Globe for Tool Designing & Development



You Name It, We Make It



CRNO Strip Laminations

Mixi Rotor Stampings



E & I Laminations



Industrial Motor Stampings



Motor Stampings for Electric Vehicles



High Speed Stators



PPGI Coils

# DEV's Major Customer Clientele



DEV COMPONENTS  
PRIVATE LIMITED

Since 1991



CRNGO Slit Coils



CRCA Coils  
CRGO Coils  
CRNGO Coils  
CRGO Pup Coils  
CRNGO Pup Coils  
GI Coils



PPGI Coils

|  |  |  |  |  |
|--|--|--|--|--|
|  |  |  |  |  |
|  |  |  |  |  |
|  |  |  |  |  |
|  |  |  |  |  |

You Name It, We Make It



CRNO Strip Laminations

Mixi Rotor Stampings



E & I Laminations



Industrial Motor Stampings



Motor Stampings for Electric Vehicles



High Speed Stators

PPGI Coils



Manufacturers of Motor Stampings, Electrical Laminations  
E&I Strip Laminations, Mitre Cut Laminations & Special Components

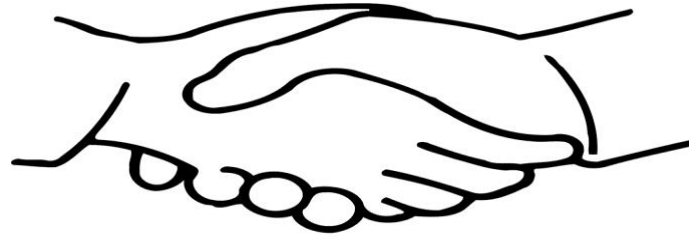

Thank You &  
Look forward to Serve

